

# PARASCOPE®

TELESCOPING WATER FEATURE  
FOR FIBERGLASS POOLS

## INSTALLATION MANUAL

### Parascope Parts

Item	Part Number	Description
1	005-059-2502-XX	Bubbler Nozzle
2	005-059-2503-XX	Flower Nozzle
3	005-059-2504-XX	Umbrella Nozzle
3A	**	Umbrella Top
3B	**	Umbrella Cap
3C	**	Umbrella Threaded Insert
4	**	Retainer
5	**	Body
6	**	Body Adapter
7	**	Bubbler Shaft 40"
8	**	Flower Shaft 45"
9	**	Umbrella Shaft 53"
10	**	Construction Cap
11	004-627-5452-00	Fountain Tool
12	**	Plastic Stops
13	**	Housing Shaft Label

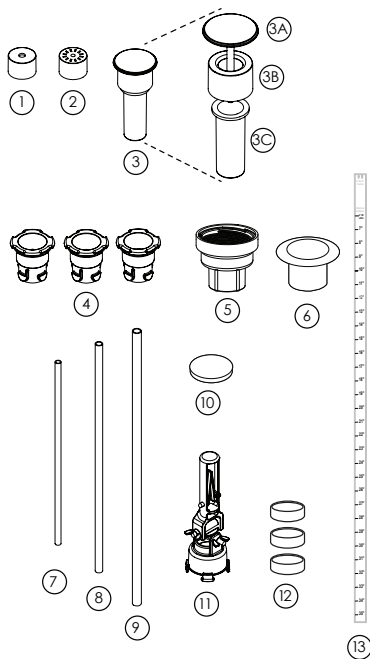

004-027-8718-00 REV 061316

US and Foreign patents and patents pending see [www.1paramount.com/about/patents/](http://www.1paramount.com/about/patents/)

295 East Corporate Place • Suite 100 • Chandler, AZ 85225

Toll Free: 1.800.621.5886 • Phone: 480.893.7607

Fax: 480.753.3397

Paramount@1Paramount.com • [www.1Paramount.com](http://www.1Paramount.com)

  
**Paramount**  
Pool Life. Simplified.

# PARASCOPE FIBERGLASS POOL INSTALLATION

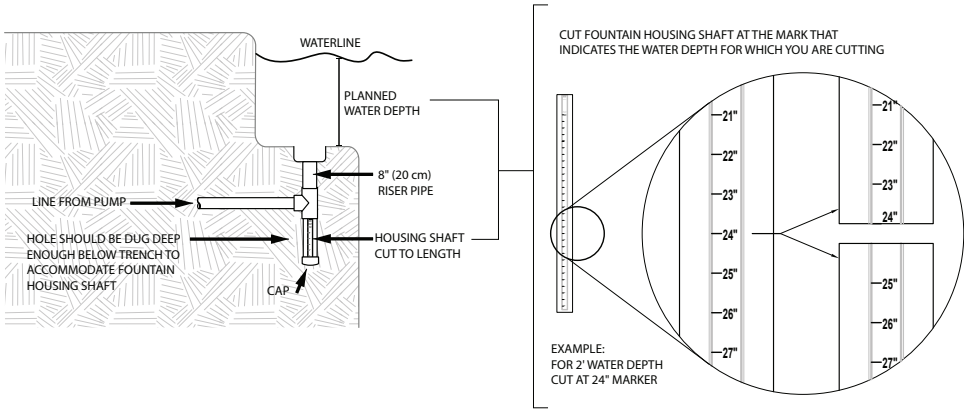

1. Note the location of the Parascope body/s that are fiberglassed into the pool for the Parascope. Dig an area below the body of the Parascope that is 8" (20 centimeters) plus the distance of the housing after it has been cut to proper length. The housing will need to be long enough to accommodate the longest fountain riser (umbrella).

2. Dig a trench from the valve/s for the feed line/s for balancing of the Parascope/s (see page 3) to each location at a depth to be able to connect a pipe/s to the plumbing for each of the Parascope housing when installed.

**3. NOTE:** Maximum water depth that they can be installed is 38" (196cm).

4. Cut the Fountain Housing Shaft at the marker indicating your water depth to minimize the depth of the hole for the shaft, however this step is optional. Note: Scale on pipe is in inches.

5. Remove the sticker from the Fountain Housing Shaft to ensure proper seal to the tee. Glue the 8" (20cm) pipe to the top of the tee. Glue housing shaft to the bottom of the tee. Glue a cap on the bottom of the housing pipe. With the tee pointing towards the feed line. Glue it to the Parascope body on the pool.

6. Each Fountain must be fed by a separate plumbing circuit with a gate valve to allow for individual adjustment.

7. Backfill the plumbing trenches and hold making sure to maintain the vertical alignment of the Parascope.

**NOTE:** If the Fountain Housing is not plumbed vertically it will not retract properly. Never plumb the fountain on a sloped surface.

**NOTE:** Pressure test plugs are available for the Parascope step/bench bulkhead fitting (part number 004-627-1642-00) to pressure test the plumbing which is recommended by Paramount.

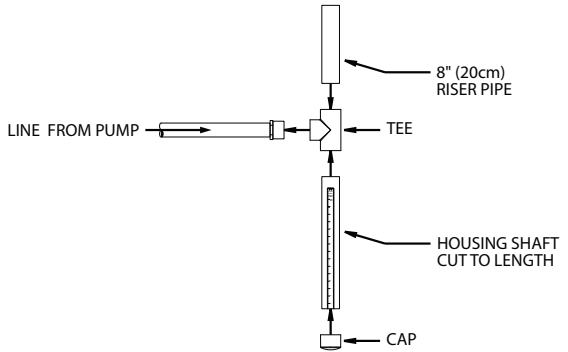

# PARASCOPE FOUNTAIN MANIFOLD PLUMBING

## With In-floor Cleaning System

1. The feed line to the Parascope should draw water from the line to the wall returns. Do not plumb it in line with the in-floor cleaning system. A 3-way valve should be used to turn on either the returns or the in-floor cleaning system.
2. Each fountain that is installed should be run with its own gate valve to allow adjustment of water flow to each fountain individually for the desired effect.
3. **DO NOT** use a 2-way or 3-way valve in place of the gate valve to the fountains. 2-way and 3-way valves do not easily make minor adjustments and may damage the fountain heads.
4. A 2-way ball valve must be plumbed between the tee to the last fountain and the wall returns so the fountains' water heights may be adjusted individually.

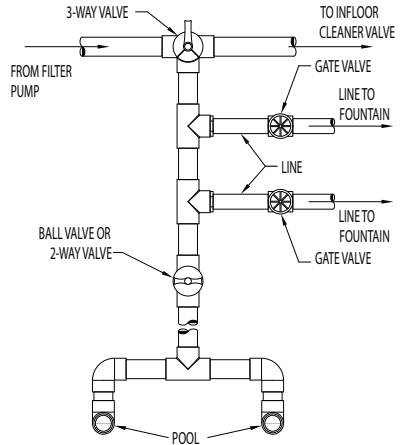

## With Wall Returns - No In-floor System

1. Each fountain that is installed should be run with its own gate valve to allow adjustment of water flow to each fountain individually for the desired effect.
2. **DO NOT** use a 2-way or 3-way valve in place of the gate valve to the fountains. 2-way and 3-way valves do not easily make minor adjustments and may damage the fountain heads.
3. A 2-way ball valve must be plumbed between the tee to the last fountain and the wall returns so the fountains' water heights may be adjusted individually.

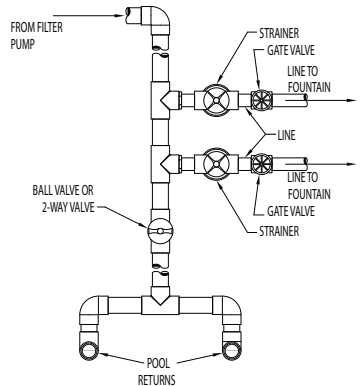

## With Wall Returns & Water Features

1. Fountains using a booster pump must have a strainer such as a Jandy Energy Filter (Part# 3456) between the pump and the fountains.
2. If a booster pump is used to run water features in the pool it is imperative to have a means of bleeding off the excess water that does not go through the fountains. This can be accomplished by adding other water features and wall returns.
3. Each fountain that is installed should be run with its own gate valve to allow adjustment of water flow to each fountain individually for the desired effect.
4. **DO NOT** use a 2-way or 3-way valve in place of the gate valve to the fountains. 2-way and 3-way valves do not easily make minor adjustments and may damage the fountain heads.
5. A 2-way ball valve must be plumbed between the tee to the last fountain and the wall returns so the fountains' water heights may be adjusted individually.

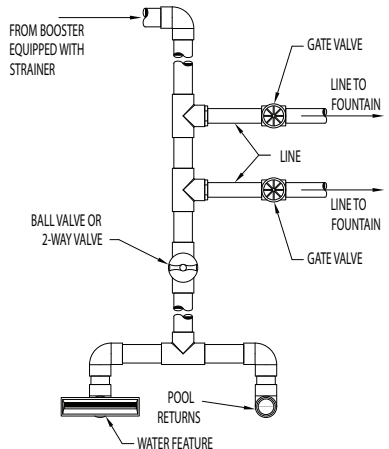

# PARASCOPE FOUNTAIN START UP

1. If installed, remove test plug from fountain and blow out the lines to remove any construction debris that may be in the pipes.
2. Glue the plastic stops on the end of the fountain shafts Fig.2 . Set the end of the fountain shaft with the stopper down over the fountain body and mark the water level on the shaft. Fig. 1
3. Transfer the water level mark to the other two shafts. Fig. 2

Fig. 1

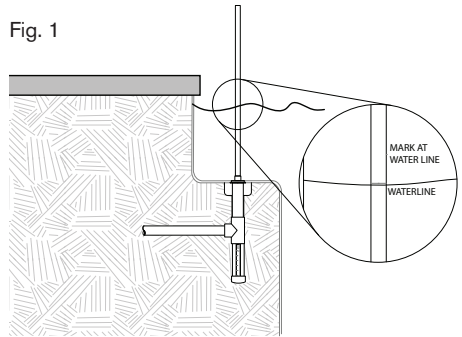

- a. Using the longest 53" shaft, measure and mark an additional 13 1/4 inches away from the stopper end.
  - b. Using the 45" shaft, measure and mark an additional 5 3/4" away from the stopper end
  - c. Using the 40" shaft, measure and mark an additional 3/4" away from the stopper end.
4. Cut all three fountains at the farthest mark from the stopper end.

Fig. 2

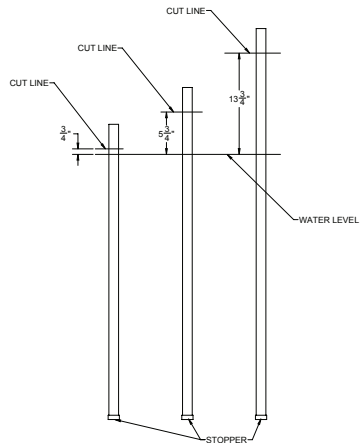

5. Insert each fountain shaft through a fountain retainer so the bottom of the fountain retainer is next to the stopper that is glued to the shaft. Fig. 3
6. Umbrella fountain Fig. 4
  - a. Select the longest fountain shaft.
  - b. Put a small dab of PVC glue on the outside of the threaded insert and press into the shaft opposite the stopper end.
  - c. Glue the umbrella end-cap over the outside of the fountain shaft, or same end as the threaded insert.
  - d. Wipe off any excess glue.
  - e. Thread the umbrella into the threaded insert until you have a 1/16" gap. When installed balance flow and gap to desired effect.

## 7. Flower fountain Fig. 5

- a. Select the medium length fountain shaft
- b. Glue the flower cap over the end of the fountain shaft opposite the stopper.
- c. Wipe off any excess glue.

## 8. Bubbler fountain Fig. 6

- a. Select the shortest length fountain shaft.
- b. Glue the bubbler cap over the end of the fountain shaft opposite the stopper.
- c. Wipe off any excess glue.

9. Install the fountain assembly Fig. 7 into the fountain body in the pool using the 4-pronged nozzle tool.

